



IN-PRESS

Industrial Style Digital Pressure Meters and Controllers

› Introduction

Bronkhorst High-Tech B.V., the European market leader in thermal Mass Flow Meters/Controllers and Electronic Pressure Controllers, has many years experience in designing and manufacturing precise and reliable measurement and control devices. With a wide range of instruments, Bronkhorst offers innovative solutions for many different applications in many different markets.

The instruments are made to customers' specification, in various styles, suitable for use in laboratory, industrial and hazardous areas.

› IN-PRESS series for industrial environments

The digital electronic Pressure Meters and Controllers of the IN-PRESS series are of rugged design (IP65) for use in pilot and production plants in industrial environments or even Zone 2 hazardous areas, with optional ATEX Category 3 approval. The instruments have a well-proven compact thru-flow design and are available in pressure ranges from 2...100 mbar up to 8...400 bar, both in absolute and relative (gauge) pressure. The pressure controller performs with high accuracy and repeatability and should be specified for forward or backward pressure control.

› State of the art digital design

The IN-PRESS Pressure Meter/Controller is equipped with a diaphragm type piezoresistive pressure sensor and a digital pc-board, as standard offering high accuracy, stability and reliability. The main digital pc-board contains all of the general functions needed for measurement and control. In addition to the standard RS232 output the instruments also offer analog I/O. As an option, an integrated interface board provides DeviceNet™, CANopen®, PROFIBUS DP, FLOW-BUS, Modbus RTU/ASCII, PROFINET, EtherCAT®, Modbus TCP, EtherNet/IP or POWERLINK protocols.

› Pressure Controllers for every application

The pc-board of an IN-PRESS Pressure Meter features integrated, adaptable PID control for fast and smooth control of any electronically driven valve. With reference to the specific fields of application there are different series of unique Bronkhorst proportional, electromagnetic control valves. There is a standard direct acting valve for common applications, a pilot operated valve for high flow rates, the so-called Vary-P valve that can cope with up to 400 bar ΔP and a bellows valve for applications with very low differential pressure.

› IN-PRESS features

- ◆ Weatherproof IP65 housing
- ◆ High accuracy and repeatability
- ◆ High pressure capability up to 400 bar
- ◆ Stable control even at varying process volumes
- ◆ Optional: ATEX approval Cat.3, Zone 2
- ◆ Analog I/O signals: 0...5(10) V / 0(4)...20 mA
- ◆ Digital communication:
 - ◆ RS232, DeviceNet™, CANopen®
 - ◆ PROFIBUS DP, FLOW-BUS, Modbus RTU/ASCII
 - ◆ PROFINET, EtherCAT®, Modbus TCP, EtherNet/IP, POWERLINK

› Fields of application

- ◆ Process pressure control in food, pharma and (petro-) chemical industries
- ◆ Fermenter pressure control (Biotechnology)
- ◆ Fuel Cell technology
- ◆ Protective gas pressure control in extrusion moulding processes



IN-PRESS P-502CI+F-001AI Back Pressure Controller

› Measuring principle

The Bronkhorst® IN-PRESS pressure sensor is a piezoresistive bridge on the surface of a silicon chip. This chip is drilled out on its reverse side, giving the inside of the chip the form of a pressure diaphragm, whose thickness determines the pressure range.

When a pressure acts on this chip, the diaphragm flexes, and the resistor values of the bridge alter in proportion to the pressure. The measuring cell is separated from the external pressure by a thin, sensitive stainless steel diaphragm, and the sealed off cavity between diaphragm and cell is filled with oil.

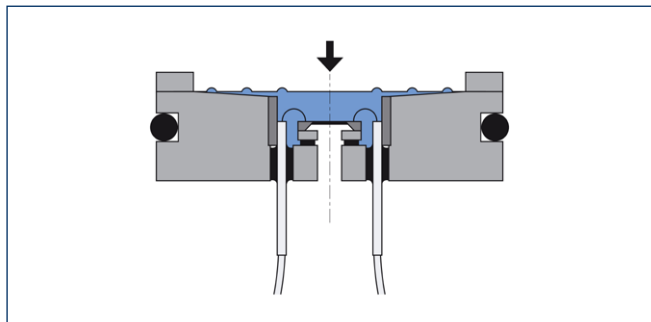

Cross sectional drawing of a pressure sensor

› Dimensional drawings

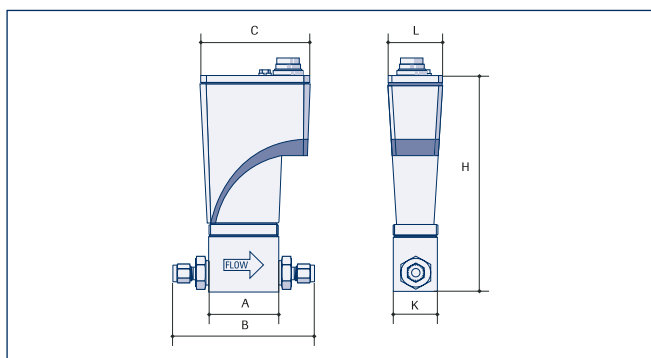

IP65 Pressure Meter

Model	A	B	C	H	K	L	Weight (kg)
P-502CI / P-512CI / P-522CI / P-532CI (¼")	47	104	74	145	30	36	1,1

Dimensions in mm.

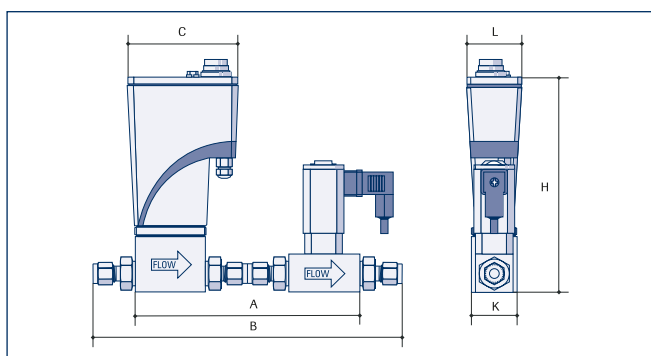

IP65 Forward or Back Pressure Controller

Model	A	B	C	H	K	L	Weight (kg)
P-502CI+F-001AI / P-512CI+F-011AI (¼")	150	207	74	145	30	36	1,6

Dimensions in mm.

› Configurations

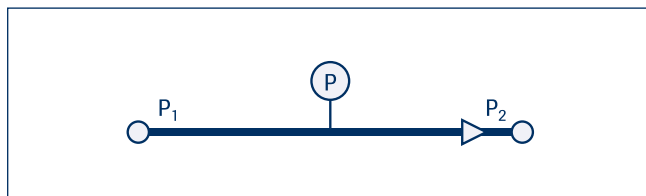

Pressure measurement

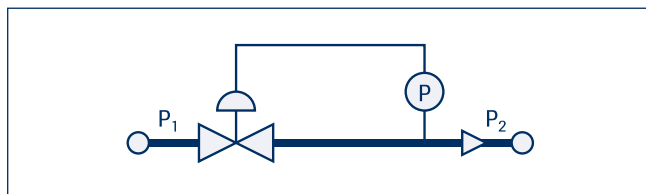

Forward pressure control

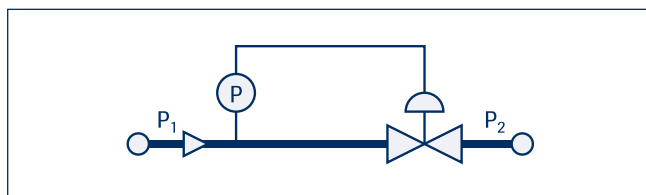

Back pressure control



P-502CI Pressure Meter

› Examples of some applications

It is of course impossible to picture the possible number of applications. Here is a limited quantity of basic examples, which are often seen with some variations. However, identical or similar configurations are used in totally different applications. Therefore please consider the ones pictured here as examples for solving common applications.

› Pressure control with adjustable flow

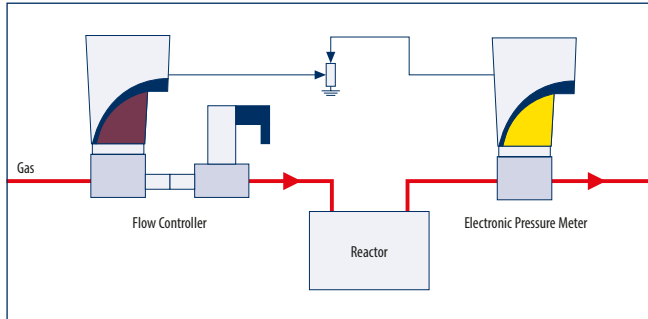

The control valve of the IN-FLOW Mass Flow Controller (MFC) forms a closed loop pressure control system with the IN-PRESS Pressure Transducer: the Mass Flow Meter of the MFC measures the required flow rate to maintain the set pressure level. The setpoint voltage divider enables the user to adjust the maximum flow to build up desired pressure levels. Restriction of the maximum flow may for safety reasons be important in certain processes.

› Compensation of atmospheric pressure changes

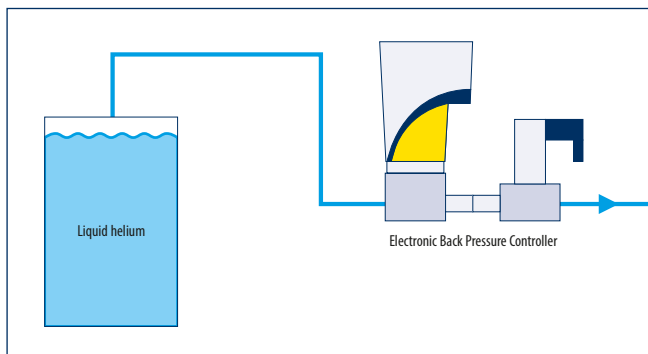

Superconducting coils, which are used to generate magnetic fields, are cooled by liquid helium. Depending on the temperature exchange gaseous helium should be vented. With a manually controlled outlet the variation of the atmospheric pressure disturbs the magnetic field. By using an IN-PRESS Back Pressure Controller the pressure for the superconducting coils is kept constant, thus eliminating the negative effects of atmospheric pressure variations.

› Back pressure control independent of gas mix and total flow

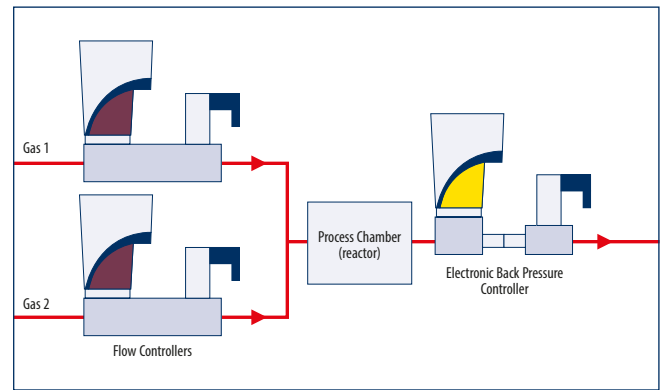

A gas mixture is formed by IN-FLOW Mass Flow Controllers. In a process chamber the effect of the catalyst on certain reactions is tested. The pressure in the process chamber is controlled to the desired level by means of an IN-PRESS Back Pressure Controller, independent of the total flow and/or the composition of the mixture.

› Pressure control combined with flow measurement

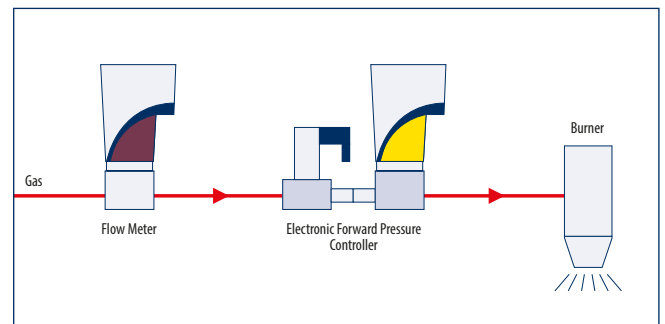

This arrangement of an IN-FLOW Mass Flow Meter with, in series, an IN-PRESS Forward Pressure Controller is used in burner test applications, or tests to check the inlet pressure dependence of the capacity of mechanical pressure regulators, or the tolerance on the bore of orifices, etc.

› Back Pressure Control in Fuel Cell Systems

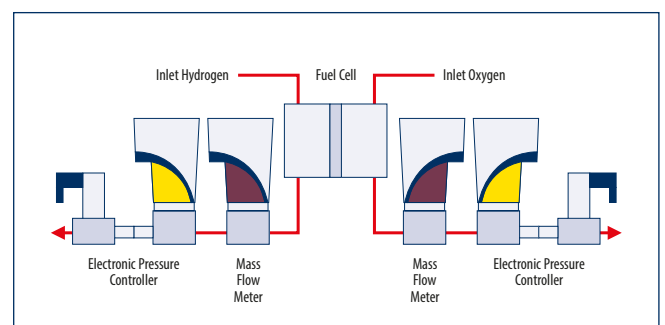

In Fuel Cell systems Electronic Pressure Controllers are used to maintain the pressure at optimum process conditions, even at variable flow rates. The IN-PRESS Back Pressure Controllers keep the H₂ and O₂ pressures equal and very stable, ensuring that the membranes of the cells are not damaged by large pressure differences.

» Technical specifications

Measurement / control system

Accuracy (incl. linearity and hysteresis)	±0,5% of full scale (FS)
Pressure rangeability	measurement: 1:50 (2...100%) control (with flow range 1:50) back pressure control: 1:5 forward pressure control: 1:20
Repeatability	≤ 0,1% RD
Response time sensor	2 msec
Control stability	≤ ±0,05% FS (typical for 1 l _v /min N ₂ at specified process volume)
Operating temperature	-10...+70°C; for ATEX Cat. 3: 0...50°C
Temperature sensitivity	0,1% FS/°C
Leak integrity	tested < 2 x 10 ⁻⁹ mbar l/s He
Attitude sensitivity (at 90° change)	< 0,3 mbar
Warm-up time	negligible

Mechanical parts

Material (wetted parts)	stainless steel 316L or comparable
Process connections	compression type or face seal couplings
Seals	standard: Viton® options: EPDM, Kalrez® (FFKM)
Ingress protection (housing)	IP65

Electrical properties

Power supply	+15...24 Vdc		
Max. power consumption	Supply	at voltage I/O	at current I/O
Meter	15 V 24 V	95 mA 65 mA	125 mA 85 mA
Controller	15 V 24 V	290 mA 200 mA	320 mA 215 mA
Extra for fieldbus (if applicable)	15 V < 75 mA 24 V < 50 mA		
Analog output/command	0...5 (10) Vdc or 0 (4)...20 mA (sourcing output)		
Digital communication	standard: RS232 options: CANopen®, DeviceNet™, EtherCAT®, PROFIBUS DP, PROFINET, Modbus RTU, ASCII or TCP/IP, EtherNet/IP, POWERLINK, FLOW-BUS		

Electrical connection

Analog, RS232	8 DIN (male);
PROFIBUS DP	bus: 5-pin M12 (female); power: 8 DIN (male)
Modbus-TCP, EtherNet/IP, POWERLINK, EtherCAT®, PROFINET	bus: 2 x 5-pin M12 (female) (in/out); power: 8 DIN (male)
DeviceNet™, CANopen®	5-pin M12 (male)
Modbus-RTU/ASCII, FLOW-BUS	5-pin M12 (male)

Technical specifications subject to change without notice.

Calibration

References verified by an ISO 17025 calibration laboratory, directly traceable to Dutch and international standards.

» Models and pressure ranges

Electronic Pressure Transducers (EPT)

Models	Pressure ranges (abs/rel)	
P-502CI	min. 2...100 mbar	max. 1,28...64 bar
P-512CI	min. 1,28...64 bar	max. 2...100 bar
P-522CI	min. 2...100 bar	max. 4...200 bar
P-532CI	min. 4...200 bar	max. 8...400 bar

Electronic Pressure Controllers (EPC)

Models		Pressure ranges (abs/rel)	
P-502CI + F-001AI ¹⁾	(back pressure control)	min. 20...100 mbar	max. 12,8...64 bar
F-001AI ¹⁾ + P-502CI	(forward pressure control)	min. 5...100 mbar	max. 3,2...64 bar

¹⁾ Separate control valve with $Kv\text{-max} = 6,6 \times 10^{-2}$

For ranges of 100, 200 or 400 bar rated pressure controllers and for low-ΔP control applications with Kv-values up to 1,0 please contact factory.

» Model number identification

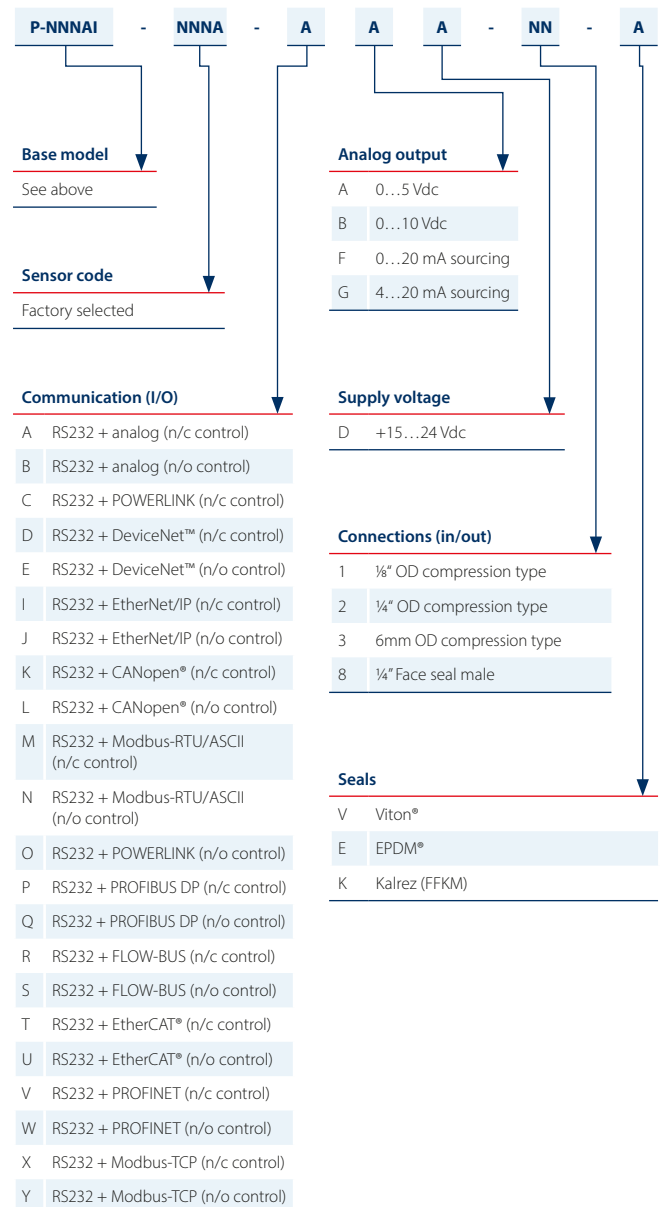

Process Pressure Controllers - P-8x2CI Series

Principle of operation

The Process Pressure Controller consists of a piezo-resistive pressure sensor and two direct acting, solenoid control valves. The instrument has a gas inlet for pressurisation, a pressure relief outlet and a system outlet. While pressurizing the system - this will normally be a static volume - the pressure sensor and the inlet valve operate as a forward pressure controller and the relief valve remains shut. When the system requires depressurisation, the inlet valve is shut and the pressure sensor in combination with the relief valve will act as back pressure controller. This dual valve construction is a compact, economical alternative to configurations where forward pressure controllers are combined with separate bleed ports and relief valves. It is considered as a great advantage that the relief valve does not continuously vent to the atmosphere. Furthermore the system can be set for either fast or smooth controlled (de)pressurization.

Configuration

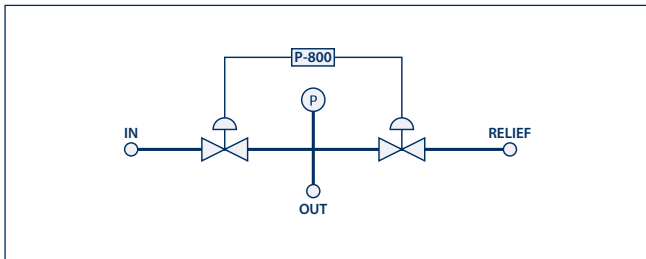

Process Pressure Control

Features P-8x2I Series

- ◆ Pressure up to 200 bar
- ◆ Dual valve pressure control (inlet/relief)
- ◆ For absolute or gauge pressure
- ◆ High accuracy and repeatability
- ◆ Low gas consumption (no gas bleed)
- ◆ Rugged, weatherproof housing (IP65, dust and waterproof)
- ◆ On-board PID controller for pressure control
- ◆ Analog, RS232 and fieldbus communication

Application: Automated dome loaded back pressure regulator

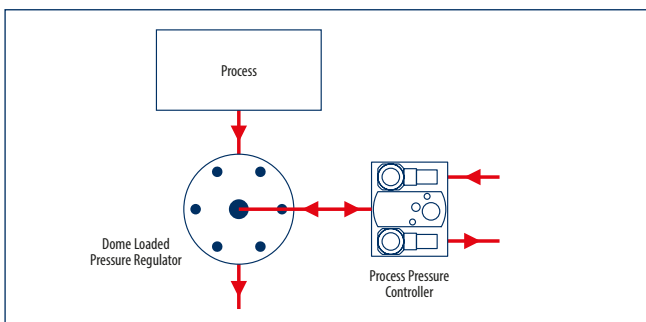

Dome loaded pressure regulators are often used to process aggressive reactants and by-products at high temperatures. For these severe applications, dome valves can be manufactured from chemically inert materials such as SS316, Hastelloy, Zirconium and Monel. For the automation of dome loaded back pressure regulators, P-8x2I instruments can be applied to control the position of the membrane to open or close the orifices of the dome loaded regulator, thereby releasing gas or liquids from the process as to keep the process pressure at a constant level.

Dimensional drawings

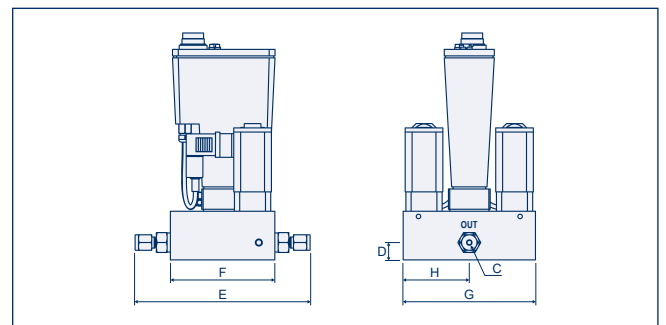
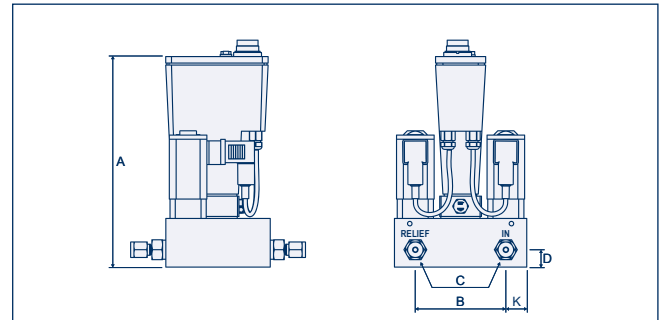

Model	A	B	C	D	E	F	G	H	K	Weight (kg)
P-802CI / P-812CI / P-822CI (1/4")	151	65	G 1/8"	12.5	130	75	95	47.5	15	2,8

Dimensions in mm.



IN-PRESS P-812CI Industrial Process Pressure Controller

Technical specifications

Measurement / control system

Accuracy (incl. linearity and hysteresis)	± 0,5% of Full Scale (FS)
Pressure control rangeability	1:20 with flow range 1:50
Repeatability	≤ 0,25% RD
Response time sensor	2 msec
Max. Kv-value	1,56 x 10 ⁻³
Max. pressure difference (ΔP)	P-802CI: 64 bar (d) P-812CI: 100 bar (d) P-822CI: 200 bar (d)
Max. flow	approx. 20 l _v /min N ₂
Control stability	≤ ± 0,1% FS (typical for 100 ml _v /min N ₂ at specified process volume)
Temperature range	-10...+70°C
Temperature sensitivity	< ± 0,1% FS/°C
Leak integrity (outboard)	tested < 2 x 10 ⁻⁹ mbar l/s He
Attitude sensitivity (at 90° change)	< 0,3 mbar
Warm-up time	negligible

Mechanical parts

Material (wetted parts)	stainless steel 316L or comparable
Process connections	compression type or face seal couplings
Seals 64/100 bar version	static and plungers: Viton® / EPDM / Kalrez®
Seals 200 bar version	static: Viton®, plungers: FKM
Ingress protection (housing)	IP65

Electrical properties

Power supply	+15...24 Vdc ±10%		
Power consumption (based on N/C valve)	Supply	at voltage I/O	at current I/O
	15 V	290 mA	320 mA
	24 V	200 mA	215 mA
Extra for fieldbus: (if applicable)	PROFIBUS DP add 53 mA (15 V supply) or 30 mA (24 V supply) DeviceNet™ / CANopen® add 48 mA (24 V supply)		
Analog output (0...100%)	0...5 (10) Vdc, min. load impedance > 2 kΩ; 0 (4)...20 mA (sourcing), max. load impedance < 375 Ω		
Analog setpoint (0...100%)	0...5 (10) Vdc, min. load impedance > 100 kΩ; 0 (4)...20 mA, load impedance ~250 Ω		
Digital communication	standard: RS232 options: PROFIBUS DP, DeviceNet™, CANopen®, Modbus RTU/ASCII, FLOW-BUS		

Electrical connection

Analog, RS232	8 DIN (male);
PROFIBUS DP	bus: 5-pin M12 (female); power: 8 DIN (male)
DeviceNet™, CANopen®	5-pin M12 (male)
Modbus-RTU/ASCII, FLOW-BUS	5-pin M12 (male)

Technical specifications subject to change without notice.

Calibration

References verified by an ISO 17025 calibration laboratory, directly traceable to Dutch and international standards.

Models and pressure ranges

Process Pressure Controller (PPC)

Models	Pressure ranges (abs/rel)	
P-802CI	Min. 17,5...350 mbar	Max. 3,2...64 bar
P-812CI	Min. 3,2...64 bar	Max. 5...100 bar
P-822CI	Min. 5...100 bar	Max. 10...200 bar

Model number identification

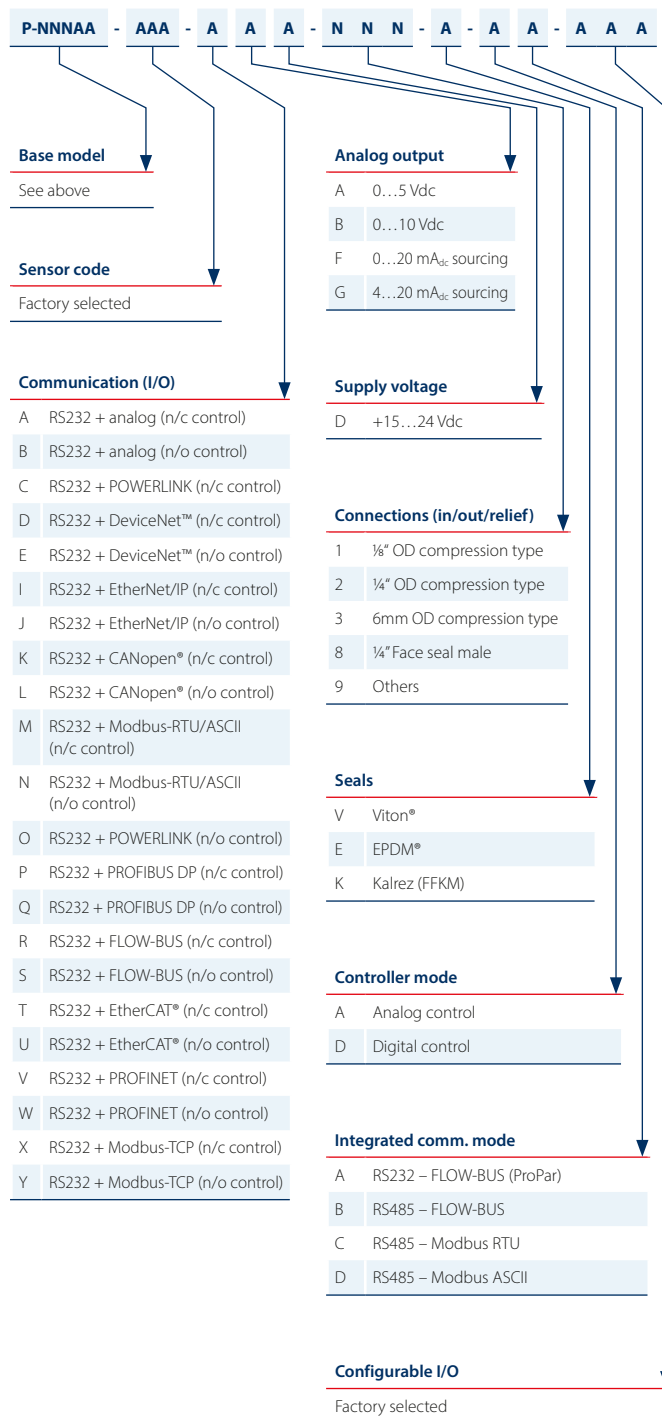



Representantes / Distribuidores Exclusivos

 Argentina

Tel: (+54 11) 5352 2500

Email: info@dastecsrl.com.ar

Web: www.dastecsrl.com.ar



Bronkhorst High-Tech designs and manufactures innovative instruments and subsystems for low-flow measurement and control for use in laboratories, machinery and industry. Driven by a strong sense of sustainability and with many years of experience, we offer an extensive range of (mass) flow meters and controllers for gases and liquids, based on thermal, Coriolis and ultrasonic measuring principles. Our global sales and service network provides local support in more than 40 countries. Discover Bronkhorst®!

www.bronkhorst.com

Bronkhorst High-Tech B.V.
Nijverheidsstraat 1a
NL-7261 AK Ruurlo, The Netherlands

Tel. +31 573 458800
info@bronkhorst.com



9.60.037H L2401698 ©Bronkhorst®